

LS42

MIDI AUDIO ROUTER & SWITCHER

4.0 - USER MANUAL

Characteristics

LS42 is a multiple MIDI switcher which incorporates the functions of 4 audio loopers - suitable for pedal effects commutation - and 2 pure switches for the on/off management of remote control devices (for example the change of amplifiers channel, multieffects by-pass etc.)

LS42 functioning principle is based on the use of ADVANCETUBETECH exclusive technology which permits a SOFT function absolutely "click-less" during commutation: this guarantees an absolute TRUEBYPASS transparency, thanks to the use of very high quality passive components (such as ampoule REED relays and resistors) as regard the circuits crossed by audio signal.

**** never connect LS42 to power signals (for example audio power amps, speaker out).**

SOFT FUNCTION

LS42 soft function, selectable and memorizable independently on each memory location, permits to carry out soft commutations, without any kind of insertion noise (click). This action, besides the absolute silent commutation, inserts and disconnects the device managed through a short ascent/descent gradual slope (70/100mS) which creates a "cross-fade" effect, making the input of the selected loop more pleasant (for example the connection of a pedal effect).

MIDI MANAGEMENT

LS42 is managed via MIDI through a pedal, a sequencer or any MIDI device able to send messages of program change/ control change according to standard MIDI.

It consist of one MIDI IN and one MIDI THRU and, thanks to the 7 poles connector, can be powered through phantom power.

Memorization on 128 memory locations.

Programming of MIDI receiving channel for PROGRAM CHANGE (from 1 to 16 or OMNI).

Programming of MIDI receiving channel for CONTROL CHANGE on channels 15 (no-soft) or 16 (soft).

CASCADE CONNECTION

It is possible to connect more than one LS42 by MIDI IN and THRU connections for example for the management of a pedal effects set composed by more than 4 elements.

As regard PROGRAM CHANGE there are no limits in choosing numbers for cascade connection.

As regard CONTROL CHANGE there is a limit of 4 units.

"FREE"/ RACK ASSEMBLAGE

LS42 can be used in its "free format", fixed on the floor with a VELCRO or with an optional panel RP2 RACKMOUNT, mounted on rack 19".

RP2 can sustain one or two LS42 or other devices produced by ADVANCETUBETECH having the same size.



DIMENSIONS : mm 210 x 100 x 44

WEIGHT : g 650

POWER SUPPLY : 9VCC 500mA / 2,5mm standard coaxial plug

AUDIO CONNECTIONS : standard JACK 1/4"

MIDI CONNECTIONS : standard DIN 5 / 7 poles

Connection

LS42 can manage a chain of 4 loops for example 4 pedal effects, connected as in the scheme below. Let the effects always active, LS42 will provide or not the insertion, according to the set programming. SW1 and SW2 are two pure relays contacts and are able to manage any kind of on/off control: for example the channel change of an amplifier. A MIDI controller pedal, through MIDI IN of LS42, transmits the message for the program change. OP128 power supply can be activated via phantom through a 7 poles cable (MC7) from the same MIDI IN in LS42.

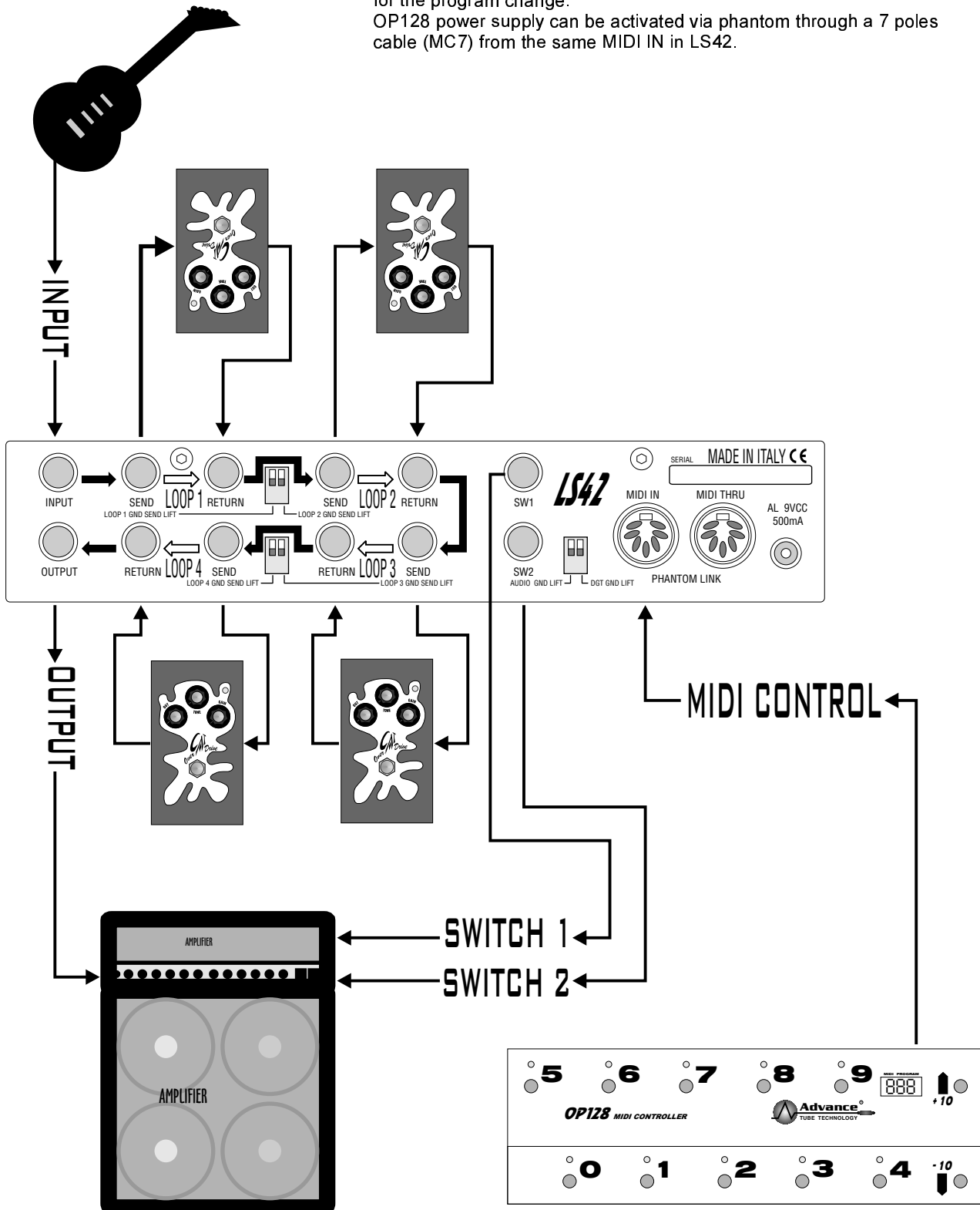

Programming

LS42 programming is very easy and intuitive.

There are two programming ways:

switches programming and MIDI SETUP programming, managed by the push-buttons.

When LS42 is on, it is set on switches programming.

In the following page MIDI SETUP mode is described.

LOOPS PROGRAMMING

- Choose a location through MIDI controller pedal
- Push once one of the 4 LOOP buttons; the led becomes green: loop connected - SOFT SWITCH mode.
- Pushing again; the led becomes red: loop connected - NO SOFT mode.
- Pushing again; the led is off: loop disconnected, the loop is bypassed (TRUEBYPASS).

Push STORE: the condition is memorized.

It is possible to set also the mixed SOFT and the NO SOFT conditions.

SWITCHES PROGRAMMING

- Choose a location through MIDI controller pedal.
- Push once one of the Swx buttons; the led becomes red: ACTIVE SWITCH (the contact is closed).
- Pushing again, the led is off: SWITCH DISCONNECTED (the contact is open)

Push STORE: the condition is memorized.

Loops and switches programming can be carried out in a sole session.

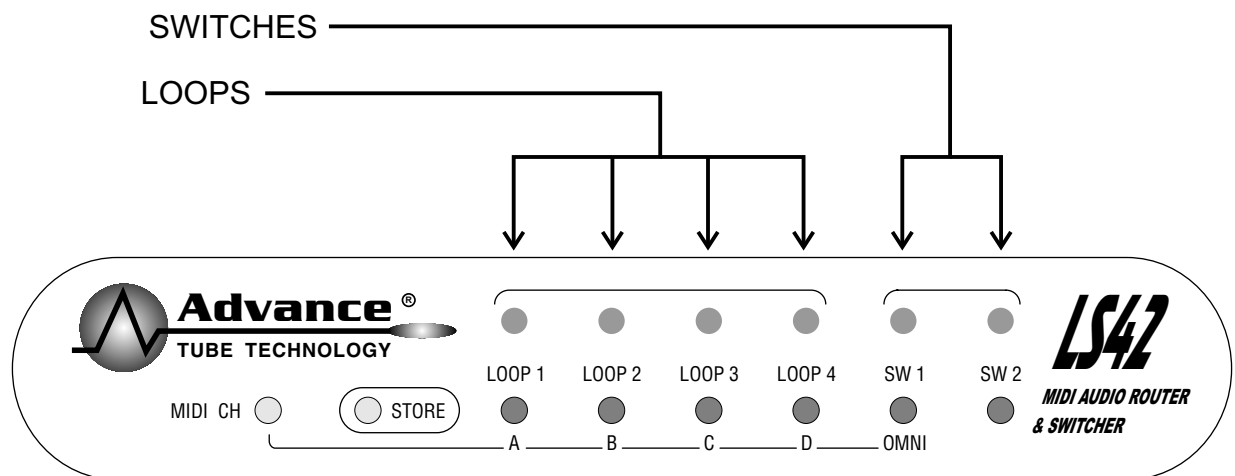

MIDI Setup

MIDI SETUP programming concerns PROGRAM CHANGE only.

For CONTROL CHANGE please refer to the follow page.

Push MIDI CH button: MIDI SETUP mode is ON and the leds flash.

Push OMNI button: all the leds flash and LS42 is able to receive from all the 16 MIDI channels.
Push OMNI again: LS42 returns to standard mode. Only the leds of A B C D buttons are active.

To select MIDI receiving channel (1...16) please refer to the table below.

	A	B	C	D		A	B	C	D
01	<input type="radio"/>	<input type="radio"/>	<input type="radio"/>	<input type="radio"/>	09	<input type="radio"/>	<input type="radio"/>	<input type="radio"/>	<input checked="" type="radio"/>
02	<input checked="" type="radio"/>	<input type="radio"/>	<input type="radio"/>	<input type="radio"/>	10	<input checked="" type="radio"/>	<input type="radio"/>	<input type="radio"/>	<input checked="" type="radio"/>
03	<input type="radio"/>	<input checked="" type="radio"/>	<input type="radio"/>	<input type="radio"/>	11	<input type="radio"/>	<input checked="" type="radio"/>	<input type="radio"/>	<input checked="" type="radio"/>
04	<input checked="" type="radio"/>	<input checked="" type="radio"/>	<input type="radio"/>	<input type="radio"/>	12	<input checked="" type="radio"/>	<input checked="" type="radio"/>	<input type="radio"/>	<input checked="" type="radio"/>
05	<input type="radio"/>	<input type="radio"/>	<input checked="" type="radio"/>	<input type="radio"/>	13	<input type="radio"/>	<input type="radio"/>	<input checked="" type="radio"/>	<input checked="" type="radio"/>
06	<input checked="" type="radio"/>	<input type="radio"/>	<input checked="" type="radio"/>	<input type="radio"/>	14	<input checked="" type="radio"/>	<input type="radio"/>	<input checked="" type="radio"/>	<input checked="" type="radio"/>
07	<input type="radio"/>	<input checked="" type="radio"/>	<input checked="" type="radio"/>	<input type="radio"/>	15	<input type="radio"/>	<input checked="" type="radio"/>	<input checked="" type="radio"/>	<input checked="" type="radio"/>
08	<input checked="" type="radio"/>	<input checked="" type="radio"/>	<input checked="" type="radio"/>	<input type="radio"/>	16	<input checked="" type="radio"/>	<input checked="" type="radio"/>	<input checked="" type="radio"/>	<input checked="" type="radio"/>

After choosing the desired SETUP push STORE or wait for a few seconds, LS42 returns to SWITCHES mode: the setup is memorized.

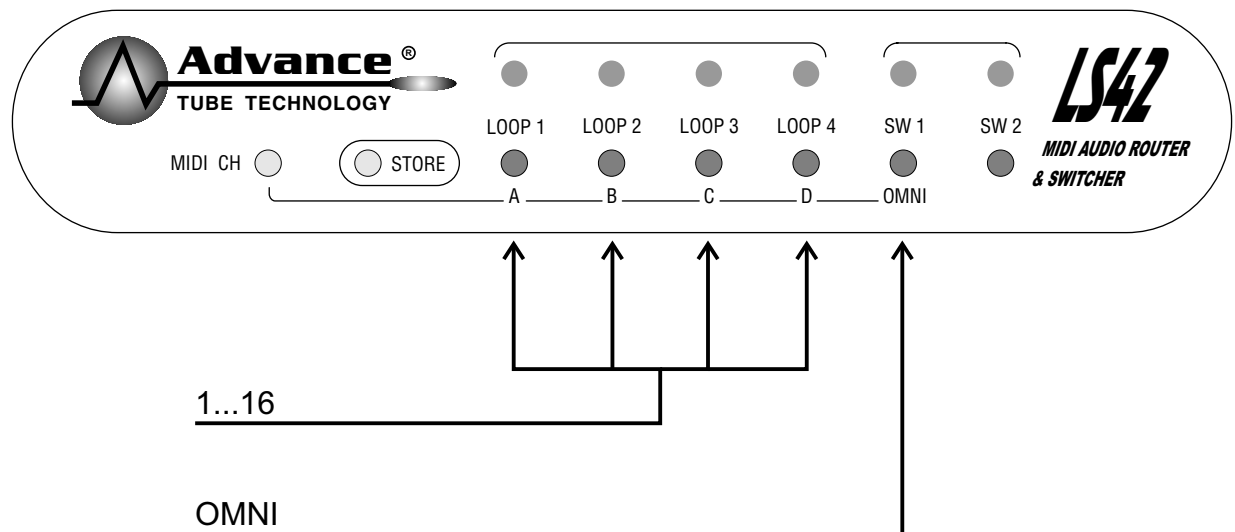

MIDI Control Change

Each one of the 4 loops and of the 2 switches of LS42 can be controlled via MIDI independently, in real time, through a device able to send messages of CONTROL CHANGE (i.e. A MIDI footcontroller having this advanced function).

LS42 reacts to CONTROL CHANGE commands in this way:

value 0=LOOP-OFF / value 127=LOOP-ON (value 0=SW-OFF / value 127=SW-ON

LS42 supports different commands for SOFT or NO SOFT function:

MIDI CH 16 receives SOFT commands and MIDI CH 15 receives NO SOFT commands.

SW1 and SW2 command is received both on CH15 and CH16.

LS42 does not receive messages of CONTROL CHANGE on MIDI channels from 1 to 14.

LS42 recognizes 6 numbers of CONTROL CHANGE***(please refer to the note at the bottom of the page) assigned to each function and distributed on 4 banks to allow the use of 4 cascade units to control 16 LOOPS and 8 SWITCHES.

LS42 is set as default on BANK "A" (control changes 80, 81, 82, 83, 84, 85) but it can be set on one of the other 3 banks according to the procedure described in the following page (BANK SET).

The table below shows the 4 banks with the correspondences between: control change number, LS42 functions, control change values and receiving MIDI channel of control change.

BANK A

control change 80 >	LOOP 1	value 0 = OFF	value 127 = ON	MIDI CH 15 = NO-SOFT	MIDI CH 16 = SOFT
control change 81 >	LOOP 2	value 0 = OFF	value 127 = ON	MIDI CH 15 = NO-SOFT	MIDI CH 16 = SOFT
control change 82 >	LOOP 3	value 0 = OFF	value 127 = ON	MIDI CH 15 = NO-SOFT	MIDI CH 16 = SOFT
control change 83 >	LOOP 4	value 0 = OFF	value 127 = ON	MIDI CH 15 = NO-SOFT	MIDI CH 16 = SOFT
control change 84 >	SW 1	value 0 = OFF	value 127 = ON	MIDI CH 15 / 16	
control change 85 >	SW 2	value 0 = OFF	value 127 = ON	MIDI CH 15 / 16	

BANK B

control change 86 >	LOOP 1	value 0 = OFF	value 127 = ON	MIDI CH 15 = NO-SOFT	MIDI CH 16 = SOFT
control change 87 >	LOOP 2	value 0 = OFF	value 127 = ON	MIDI CH 15 = NO-SOFT	MIDI CH 16 = SOFT
control change 88 >	LOOP 3	value 0 = OFF	value 127 = ON	MIDI CH 15 = NO-SOFT	MIDI CH 16 = SOFT
control change 89 >	LOOP 4	value 0 = OFF	value 127 = ON	MIDI CH 15 = NO-SOFT	MIDI CH 16 = SOFT
control change 90 >	SW 1	value 0 = OFF	value 127 = ON	MIDI CH 15 / 16	
control change 91 >	SW 2	value 0 = OFF	value 127 = ON	MIDI CH 15 / 16	

BANK C

control change 92 >	LOOP 1	value 0 = OFF	value 127 = ON	MIDI CH 15 = NO-SOFT	MIDI CH 16 = SOFT
control change 93 >	LOOP 2	value 0 = OFF	value 127 = ON	MIDI CH 15 = NO-SOFT	MIDI CH 16 = SOFT
control change 94 >	LOOP 3	value 0 = OFF	value 127 = ON	MIDI CH 15 = NO-SOFT	MIDI CH 16 = SOFT
control change 95 >	LOOP 4	value 0 = OFF	value 127 = ON	MIDI CH 15 = NO-SOFT	MIDI CH 16 = SOFT
control change 96 >	SW 1	value 0 = OFF	value 127 = ON	MIDI CH 15 / 16	
control change 97 >	SW 2	value 0 = OFF	value 127 = ON	MIDI CH 15 / 16	

BANK D

control change 98 >	LOOP 1	value 0 = OFF	value 127 = ON	MIDI CH 15 = NO-SOFT	MIDI CH 16 = SOFT
control change 99 >	LOOP 2	value 0 = OFF	value 127 = ON	MIDI CH 15 = NO-SOFT	MIDI CH 16 = SOFT
control change 100 >	LOOP 3	value 0 = OFF	value 127 = ON	MIDI CH 15 = NO-SOFT	MIDI CH 16 = SOFT
control change 101 >	LOOP 4	value 0 = OFF	value 127 = ON	MIDI CH 15 = NO-SOFT	MIDI CH 16 = SOFT
control change 102 >	SW 1	value 0 = OFF	value 127 = ON	MIDI CH 15 / 16	
control change 103 >	SW 2	value 0 = OFF	value 127 = ON	MIDI CH 15 / 16	

At any time, the sending of a message of PROGRAM CHANGE ignores any action of LS42, after the receiving of CONTROL CHANGE commands and maintains the condition memorized on presets (memory locations 0/127).

*** MIDI standard supports 127 controls of CONTROL CHANGE (1...127) to which specific control functions

or simple ON/OFF commands are assigned. Some controls are standard, but the main part are chosen by the producers.

Advantetubetech has chosen for LS42, 4 groups of control change: 80...85, 86...91, 92...97, 98...103, exclusively for ON/OFF functions.

The parameters to be set on MIDI pedal (or on other devices sending control change) besides the number of control change that, on some pedals, is available only from 1 to 120, are the following: value ON and OFF and MIDI transmission channel.

The most pedals sending control change commands through push-buttons have these default values: OFF = 0 and ON = 127 as required by LS42. For each push-button on the pedal it is necessary to set also the MIDI channel: CH 15 for NO SOFT commutation, CH 16 for SOFT commutation.

BANK Set

LS42 is set as default on BANK "A" and receives on control changes 80, 81, 82, 83, 84, 85, as described in the previous table.

Since it is necessary to perform, via MIDI, a cascade connection for more than one unit, each one of them must be set on a different bank, to avoid that the sending of a MIDI controller may activate two or more of LS42 functions.

Example: if two LS42 units should be cascade connected, via MIDI and both on BANK B, acting a button on the pedal MIDI set on control change 87, the LOOP 2 of the first unit and the LOOP 2 of the second one will be ON. Otherwise, if the first LS42 unit should be set on BANK B and the second one on BANK C, acting a button on pedal MIDI set on control change 87, only the LOOP 2 of the first unit will be ON, since the one of the second unit will correspond to control change 93.

In order to have access to the visualization function and to the bank change proceed as following described referring to the picture below.

- 1)make sure that LS42 is off and that the plug (or phantom 7 poles) is disconnected.
- 2)Push the buttons A and B and keep them pushed.
- 3)Insert the power supply plug or phantom 7 poles
- 4)release the buttons A and B

There are only 5 seconds available in order to visualize the green led corresponding to the bank set (default bank A = letter A) and to modify the condition, pushing one of the other buttons (A,B,C,D). At the due time LS42 will automatically exit from this function, memorizing the change and returning to the normal working condition.

To verify the exact setting or to change it newly, repeat the procedure from point 1.

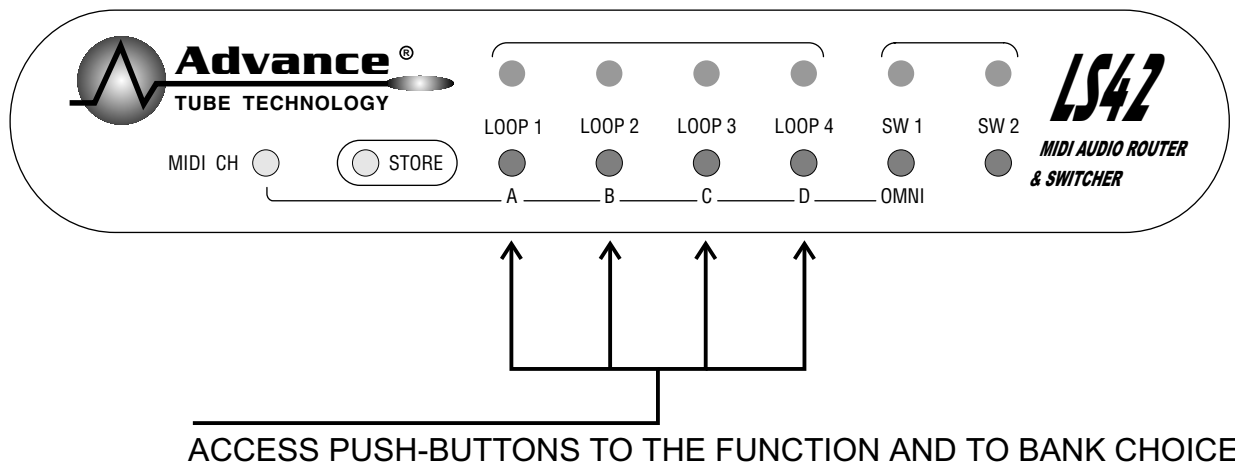

Power supply

LS42 power can be supplied through the 2,5mm coaxial plug placed on the back panel or through a DIN 7 poles connector (with the MC7 cable, optional).

For a correct functioning LS42 needs a continue 9V and a current of a least 400mA.

It is possible to use the phantom connection to power other LS42 in cascade, a MIDI pedal, or other devices working with the same voltage: the only limit is the entity of the required current (mA).

A 500mA power supply can power for example 1 x LS42 + 1 x OP128 or 1 x LS42 + 1 x MIDILoop.

To serve devices it is necessary to have a stronger power supplier, or to connect more power suppliers in parallel mode.

Earth management

LS42 has microswitches to manage earth connections, frequent cause of annoying background noises.

On the back panel there are three groups of microswitches:

In the two central groups, it is possible to manage the earth regarding the SEND of every loop

In the lateral group it is possible to manage the digital earth and the audio earth going to the metallic chassis

In case of noises it is necessary to try various configurations until the best condition is reached.

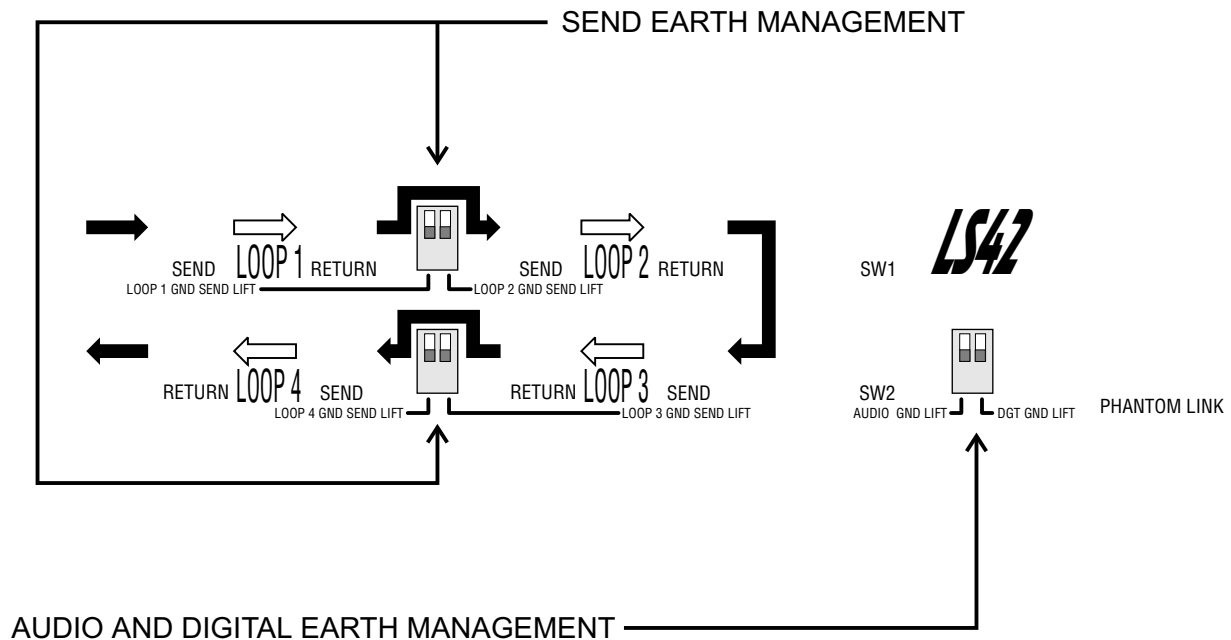

Universal Adaptor

This power supplier, included in LS42 packages, is adaptable concerning the output voltage, the polarity and the plug type.

In the package 6 plugs of different measures are supplied:
Use the one indicating 5.5 x 2.5 and insert it in the output plug coming from the power supplier according to the scheme beside.

Practically: looking at the symbol indicating the polarity with the negative pole in the center,



Insert the plug until the two arrows are met.

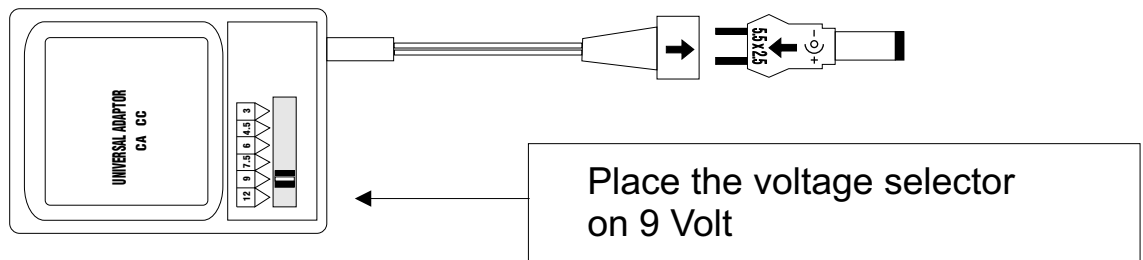
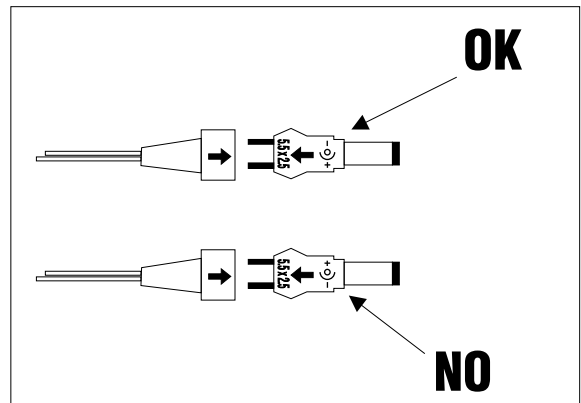



*<http://www.advancetubetech.com>
Info@advancetubetech.com*

Via Belvedere, 24
21020 GALLIATE LOMBARDO VA (ITALIA)

*Tel. +39 0332 947794
Fax +39 0332 949454*

